

NEMO TIG

FRAME WEIGHT (M)	FORK WEIGHT	BOTTOM BRACKET	MAX TYRE
1800 g	350 g	BSA	28 mm

PRO COMPETITION
AERODYNAMIC
CLIMB
REACTIVITY
COMFORT

FRAME KIT / COMPLETE BIKE

Steel is back with this competition frame made with legendary Columbus Spirit triple-buttet tubes. Entirely Made in Italy.

A classic look for this machine with contemporary details, from the head tube to the monocoque carbon fork and molded chainstays to contrast transmission force. The Tig welding technique increases the frame stiffness and allows for custom geometries.

COLOR: Racing Red



The image has the sole purpose of presenting the product. Some assembly specifications may vary.

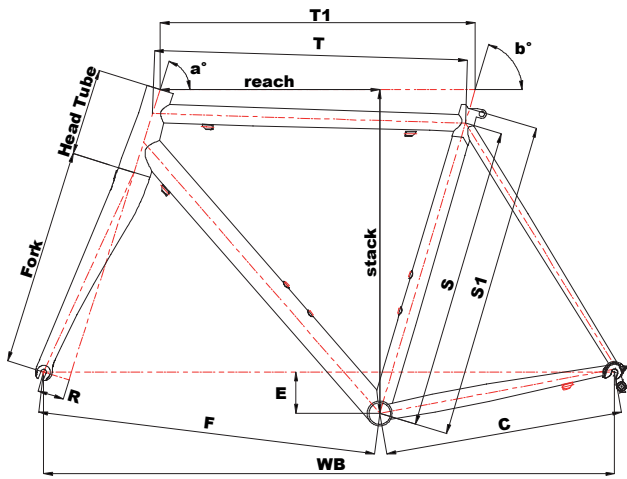

GEOMETRY

	S1	S	T1	T	H/T	A	B	R	C	F	WB	E	FORK	ST.OV	STACK	REACH
XS	480	455	510	506	110	71	74.5	45	405	572	967	70	368	735	510	369
S	510	485	520	516	120	71.5	74	45	405	573	968	70	368	760	520	371
M	540	515	535	531	145	72.5	73.5	45	405	575	969	70	368	782	547	373
L	560	535	550	545	160	73	73.5	45	405	585	980	70	368	799	564	383
XL	590	565	575	570	185	73	73	45	408	605	1003	70	368	823	587	395
XXL	610	585	590	584	210	73.5	72.5	45	410	609	1005	70	368	845	643	397

ASSEMBLY

ULTEGRA

Drivetrain	Shimano Ultegra 8000
Handlebar	Cinelli Vai
Stem	Cinelli Vai
Seatpost	Cinelli Vai Ø 27.2
Shifters	Shimano Ultegra R8000
Brakes	Shimano Ultegra R8000
Rotors	/
Ft. derailleur	Shimano Ultegra R8000
R. derailleur	Shimano Ultegra R8000
Crankset	Shimano Ultegra R8000 52/36t
Cassette	Shimano Ultegra R8000 11/30t
Chain	Shimano Ultegra 8000
Wheelset	Fulcrum Racing 600
Tyres	Pirelli PZero 700x28
Saddle	Selle Italia Novus

FRAME SPECS

Sizes	XS (48) - S (51) - M (54) - L (56) - XL (59) - XXL (61) / Made to Measure
Material	Columbus Spirit HSS Tubeset
Headset	IS 42/28.6 IS 52/40
Seatpost	Ø 27.2 mm
Seat Clamp	Integrated
BB Shell	BSA 68 mm / Press Fit 86.5 x 41 (Custom)
Ft. derailleur	Clamp Ø 31.7 mm
Routing	External
Color	Yellow Moon (+3 Custom colors and +33 Colors matt or glossy)
Tyre Clear.	up to 700x28 mm
Fork	Columbus Futura Caliper 1-1/8" - 1-1/2" Carbon Monoc.
Weight	Frame 1800 g. (size M) Fork 350 g. (uncut)
Brake	Standard Rim Brake
Dropouts ST	Front QR 100 mm - Rear QR 130 mm
Highlights	Frame / Fork / Ft. Derailleur Clamp / Headset



INTEGRATED SEAT CLAMP The lug with the integrated Nemo seat clamp permits the best connection between the seat stays and the horizontal tube offering an ideal weld surface and avoiding any stress concentration.

TAPERED HEAD TUBE & COLUMBUS FUTURA FORK The 1.5" tapered head tube with the Columbus Futura Caliper monocoque fork increases the reactivity of the frame and the handling of the bike.

WINGED DROPOUTS The beautiful 'C' Winged logo has been casted into the Nemo stainless steel dropouts to create a unique and elegant effect that increases the originality of this Italian Made frame. The dropout design is provided with a curved surface that allows an optimum tig welding of the rear stays and the possibility to adapt to all frame sizes.

