

# PRESSURE

FRAME WEIGHT (M)	FORK WEIGHT	PRESS FIT	MAX TYRE
<b>990 g</b>	<b>390 g</b>	<b>BB 86,5</b>	<b>30 mm</b>



PRO COMPETITION	
AERODYNAMIC	
CLIMB	
REACTIVITY	
COMFORT	

## FRAME KIT / COMPLETE BIKE

Born to race, this monocoque high modulus carbon T800 fiber aero road bike is designed to cut through the air. Password: integrate! The new born Cinelli aerodynamic racing frame integrates anything possible: the special aero seat tube, the custom colour FSA Vision Metron 5D AGR fully integrated aero handlebar, with integrated headset, cockpit and fork, for the cleanest cable routing solution and fastest racing geometry ever. The bicycle natural choice is for electronic groupset.

COLOR: Rock The White



The image has the sole purpose of presenting the product. Some assembly specifications may vary.

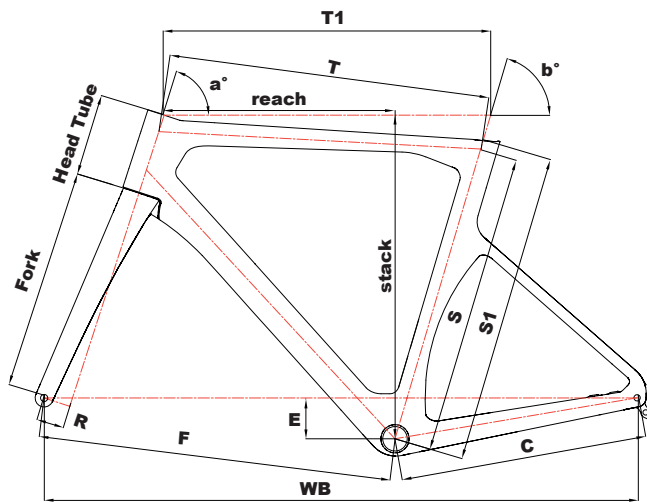

## GEOMETRY

	S1	S	T1	T	H/T	A	B	R	C	F	WB	E	FORK	STACK	REACH
XS	460	444	518	504	110	71	73.5	45	410	571	971	68	374	512	366
S	490	472	530	518	125	71.5	73.5	45	410	579	979	68	374	528	374
M	520	503	545	538	135	72	73.5	45	410	590	990	68	374	539	385
L	550	535	560	556	155	72.5	73.5	45	410	600	1001	68	374	560	394
XL	580	567	575	573	175	73	73.5	45	410	611	1011	68	374	581	403

## ASSEMBLY

	SUPER RECORD EPS	RED ETAP AXS	DURA-ACE DISC DI2	ULTEGRA DISC DI2	ULTEGRA DISC
Drivetrain	Campagnolo SR EPS	Sram Red Etap AXS	Shimano Dura-Ace R9270	Shimano Ultegra R8170	Shimano Ultegra R8020
Handlebar	FSA Metron 5D ACR	FSA Metron 5D ACR	FSA Metron 5D ACR	FSA Metron 5D ACR	FSA Metron 5D ACR
Stem	/	/	/	/	/
Seatpost	Integrated	Integrated	Integrated	Integrated	Integrated
Shifters	Campagnolo SR EPS	Sram Red Etap AXS	Shimano Dura-Ace R9270	Shimano Ultegra R8170	Shimano Ultegra R8020
Brakes	Campagnolo SR	Sram Red	Shimano Dura-Ace R9270	Shimano Ultegra R8170	Shimano Ultegra R8070
Rotors	Campagnolo 160 - 140 mm	Sram Centerline XR 160 - 140 mm	Shimano 160 - 140 mm	Shimano 160 - 140 mm	Shimano 160 - 140 mm
Ft. derailleur	Campagnolo SR EPS	Sram Red Etap AXS	Shimano Dura-Ace R9250	Shimano Ultegra R8150	Shimano Ultegra R8000
R. derailleur	Campagnolo SR EPS	Sram Red Etap AXS	Shimano Dura-Ace R9250	Shimano Ultegra R8150	Shimano Ultegra R8000
Crankset	Campagnolo SR	Sram Red Etap AXS 48/35t	Shimano Dura-Ace R9200 52/36t	Shimano Ultegra R8100 52/36t	Shimano Ultegra R8000 52/36t
Cassette	Campagnolo SR	Sram Red Etap AXS 10/28t	Shimano Dura-Ace R9200 11/30t	Shimano Ultegra R8100 11/30t	Shimano Ultegra R8000 11/30t
Chain	Campagnolo SR	Sram Force Flathead	Shimano M9100	Shimano M8100	Shimano Ultegra 8000
Wheelset	Campagnolo Bora Ultra	Fulcrum Wind 550 DB	Fulcrum Wind 550 DB	Fulcrum 600 DB	Fulcrum 600 DB
Tyres	Vittoria Zaffiro pro 700x28	Vittoria Zaffiro pro 700x28	Vittoria Zaffiro pro 700x28	Vittoria Zaffiro pro 700x28	Vittoria Zaffiro pro 700x28
Saddle	Selle Italia Novus	Selle Italia Novus	Selle Italia Novus	Selle Italia Novus	Selle Italia Novus



Disc brake and thru axle with the dropped seat stays design increase the aerodynamics alongside with the global stiffness of the frame, for best reactivity and maximum control. Pressure. Double check the bottom bracket to fully appreciate the power and meaning of this racing machine. A hint? London Calling? Smashed fender P-bass? More than enough to guess. In Italo flagship design colours.

**TOTAL INTEGRATED SOLUTION** Vision Metron 5D handlebar's ACR system, with fully integrated bar, cockpit headset and fork, coupled with the use of PU Molds in the curing for the cleanest and most efficient internal wire passage, emphasize the purest aesthetic and Pressure artwork.

**AERO SECTION ELEMENTS** Aero seat tube and dropped seat stays are functional to best aerodynamics and stiffness and join forces with the other aero elements of the frame for best control and power.

**DYNAMIC RACING GEOMETRY** The thru axle and disc brake choice with internal wire routing allows for the cleanest and fastest design, in an overall geometry which leads to the most compact and aerodynamic position of the rider.



## FRAME SPECS

Sizes	XS (46) - S (49) - M (52) - L (55) - XL (58)
Cockpit	XS 90x400 - S 100x400 - M 110x420 - L 120x420 - XL 130x440 Included
Material	Columbus Carbon Monocoque T800
Headset	IS 52/28.6   IS 52/40 FSA ACR 1-1/2" (included)
Seatpost	Aero (included) / Carbon Rail Comp. / L 300 (XS) - L 350 (S-M-L-XL)
Seat Clamp	Hidden (included)
BB Shell	Press Fit 86.5 x 41 mm
Ft. derailleur	Braze-On
Routing	Full Internal - Di2/EPS Compatible
Color	Rock The White
Tyre Clear.	up to 700x30 mm
Fork	Columbus Disc 1-1/2" Carbon Monocoque Internal Cable Routing
Weight	Frame 990g (size M) - Fork 390g (uncut)
Brake	Flat Mount Disc Brake, Rotor Size Up To 160 mm
Dropouts ST	Rear TA Ø 12x142mm - M12x165 / Front TA Ø 12x100mm - M12x120
Highlights	Extra hanger / Di2 / EPS Cable Inserts / F-R Skewers